

A-01s

*02s



PQM-1000s register map (ver 1.0.04)

1 reg = 2bytes (16bit)
short int = 16 bit
integer = 32 bit
long int = 64 bit
neg P = export
neg Q = inductive

(isolated type) Models

A-01s : RS485 Modbus RTU
A-02s : RS485 Modbus RTU + 1 output contact

casing dimension

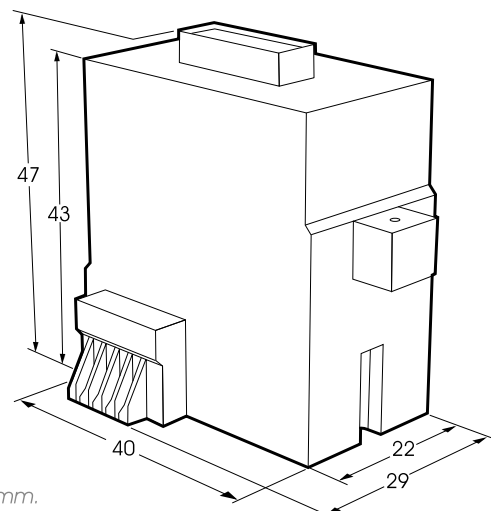
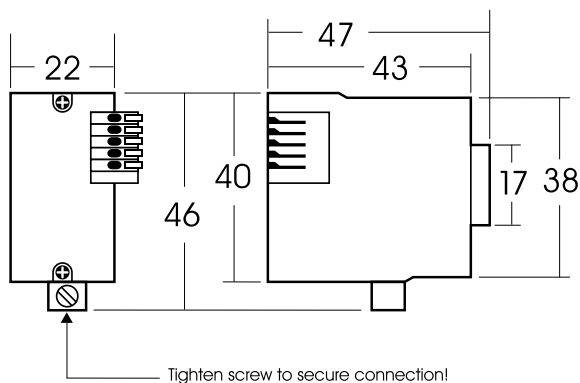

All measurement in mm.

